

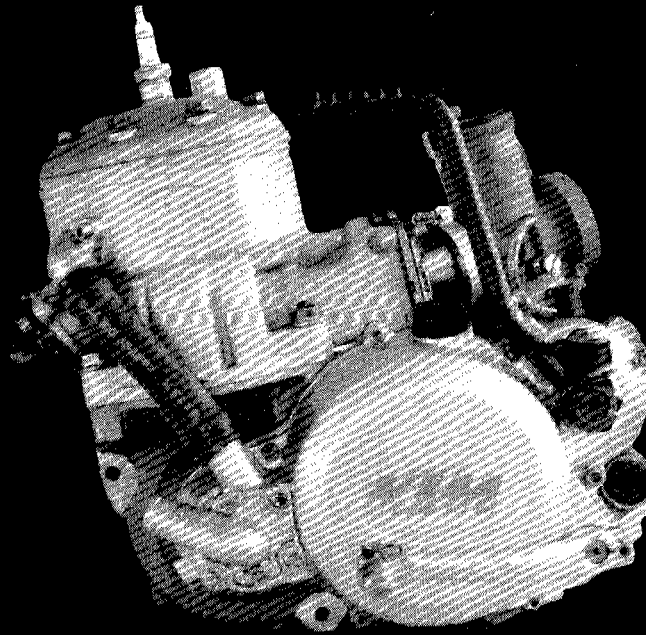

202.32



MOTOR TYP 565

Engine Type 565 '85

500 cc

TECHNISCHE DATEN

MOTOR	500/III	
BAUART	FLÜSSIGKEITSGEKÜHLTER EINZYLINDER-ZWEITAKT-OTTOMOTOR	
HUBRAUM	485 ccm	
BOHRUNG/HUB	89/78	
LEISTUNG MAX.	44 kW (60 PS)	
NENNDREHZAHL	6500/min	
KRAFTSTOFF	SUPERKRAFTSTOFF ROZ 98, MIT ZWEITAKTÖL GEMISCHT	
MISCHUNGSVERHÄLTNIS	1:40...1:50 BEI VERWENDUNG VON HOCHWERTIGEM ZWEITAKTÖL	
● MASS "X"	0,9 - 1,1 mm	
ZUNDEITPUNKT	2,1 - 2,2 mm (16,7° - 17,1°) v. OT	
ZÜNDKERZE	BOSCH W 2 CC	
ELEKTRODENABSTAND	0,6 mm	
GETRIEBESCHMIERUNG	0,6 l HYPOID-ÖL SAE 80 (SHELL SPIRAX HD 80)	
KÖHLFLÜSSIGKEIT	1,3 LITER, MISCHUNGSVERHÄLTNIS 2:1-FROSTSCHUTZMITTEL:WASSER	
ZÜNDANLAGE	KONTAKTLOS GESTEUERTE THYRISTOR-ZÜNDANLAGE	
GENERATORLEISTUNG	MX KEIN GENERATOR	MXC, XC-GS 6V 35/5/21 W
GENERATORANSCHLÜSSE		GELB 35W, WEISS 5W, GRÜN 21W

● UM NACH DEM WIEDERMONTIEREN DES ZYLINDERS DIE RICHTIGE EINSTELLUNG ZU ERHALTEN, IST FOLGENDES MASS "X" EINZUHALTEN (UNTERLEGEN VERSCHIEDEN STARKER ZYLINDERFUSSDICHTUNGEN).

BEIM MESSEN IST DER ZYLINDER NIEDERZUSPANNEN UND DER KOLBEN AUF DEN OBEREN TOTPUNKT ZU STELLEN.

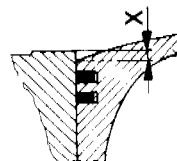

Technical Data

Engine	500/III	
Design	Liquid-cooled single-cylinder two-stroke engine	
Piston displacement	485 cc	
Bore/stroke	89/78	
Performance max.	44 kW (60 HP DIN)	
rpm at max. HP	6500	
Fuel	SUPER fuel, research octane no 98, mixed with two-stroke oil	
Oil/gasoline ratio	1:40...1:50 when using high-grade two-stroke oil	
● Dimension "X"	0,9 - 1,1 mm	
Ignition timing	2,1 - 2,2 mm (16,7° - 17,1°) BTDC	
Spark plug	BOSCH W 2 CC	
Electrode gap	0,6 mm	
Gear lubrication	0,6 l HYPOID-oil SAE 80 (SHELL SPIRAX HD 80)	
Coolant	1,3 litres mixture 2:1 of anti-freeze and water	
Ignition system	solid-state thyristor ignition system	
Generator output	MX no generator	MXC, XC-GS 6V 35/5/21 W
Generator connections		yellow 35W, white 5W, green 21W

● In order to ensure a correct fit when the cylinder is re-assembled, the dimension "X" must be maintained by using different thicknesses for the cylinder bottom gasket.

When measuring "X", the cylinder should be clamped down and the piston and the piston adjusted to the TDC position.

GETRIEBEÜBERSETZUNGEN				
PRIMAR- ÜBERSETZUNG	GETRIEBEÜBERSETZUNG			ORIG.ÜBERSETZUNG HINTERRAD
	MX-4	MX-5	MXC-5	
29:76	1. GANG	—	14:35	14:35
	2. GANG	16:24	16:24	15:24
	3. GANG	18:21	18:21	18:21
	4. GANG	20:19	20:19	20:19
	5. GANG	27:21	27:21	27:20
			14:50	MX
			14:48	MXC XC-GS

Gear ratios				
Primary ratio	Transmission			Orig.Final Drive Ratio
	MX-4	MX-5	MXC-5	
29:76	1st gear	—	14:35	14:35
	2nd gear	16:24	16:24	15:24
	3rd gear	18:21	18:21	18:21
	4th gear	20:19	20:19	20:19
	5th gear	27:21	27:21	27:20
			14:50	MX
			14:48	MXC XC-GS

VERGASER-GRUNDEINSTELLUNG	
VERGASERTYPE	55/38/101
HAUPTDÖSE	▲195 ■190
NAELEDÖSE	▲284 ■282
LEERLAUFDÖSE	▲65 ■70
DÜSENNADEL	6 L 6
NADELPOSITION	2. VON OBEN
GEMISCHREG. SCHRAUBE OFFEN	2 UMDR.
SCHIEBER	160
ZERSTÄUBER	2

Basic carburettor setting	
Carburettor type	55/38/101
Main jet	▲195 ■190
Needle jet	▲284 ■282
Idling jet	▲65 ■70
Jet needle	6 L 6
Needle position	2nd from top
Mixture adjustment screw open	2 turns
Throttle valve	160
Vaporizer	2

▲NEUER MOTOR
■EINGEFAHRENER MOTOR

▲New engine
■After break-in

TOLERANZEN - EINBAUSPIELE		Tolerances and Fitting clearances	
KOLBENEINBAUSPIEL	0,04 - 0,05 mm	piston fitting clearance	
KOLBENRING-STOSSPIEL	0,1 - 0,2 mm	piston ring end gap	
PLEUELLAGER - RADIAL	0,02 - 0,03 mm	connecting rod bearing - radial clearance	
GETRIEBEWELLEN-AXIALSPIEL	0,1 - 0,2 mm	transmission shaft end float	
KUPPLUNGSDRUCKFEDERN-LÄNGE	∅ 2,8 mm l = 38 mm	clutch springs - length	

DICHTUNGSSTÄRKEN		Gasket Thicknesses	
MOTORGEHÄUSE	0,3 mm	crank case	
KUPPLUNGSDECKEL	0,3 mm	clutch cover	
ZYLINDERFUSSDICHTUNG	NACH BEDARF / as required	cylinder bottom gasket	
LIEFERBARE FUSSDICHTUNGEN	0,2 / 0,3 / 0,5 mm	available bottom gaskets	
AUSPUFFSTUTZENDICHTUNG	1 mm	exhaust stub gasket	
ZYLINDERKOPFDICHTUNG	0,2 mm	cylinder head gasket	

ANZUGSDREHMOMENTE			Tightening Torques
ZYLINDERKOPFSCHRAUBEN	M 8	34 Nm (3,5 kpm)	cylinder head bolts
BUNDMUTTER-SCHWUNG (LINKSGEWINDE)	M 12 x 1	54 - 59 Nm (5,5 - 6 kpm)	flywheel collar nut (LH thread)
MUTTER FÜR PRIMÄRRAD	M 20 x 1,5	78 Nm (8 kpm)	nut for primary sprocket
MUTTER FÜR KUPPLUNGSMITNEHMER	M 18 x 1,5	78 Nm (8 kpm)	nut for inner clutch hub
MOTORGEHÄUSE- UND DECKELSCHRAUBEN	M 6	8 Nm (0,8 kpm)	crankcase and cover bolts

ZYLINDER / Cylinder



BILD Fig.	TEILENUMMER Part number	STK Qty	BILD Fig.	TEILENUMMER Part number	STK Qty
1	565.30.005.000	1	30	565.35.006.000	1
2	565.30.030.000	x 0,2 mm	31	0770 020200	1
2	565.30.030.100	x 0,3 mm	32	565.35.025.001	0,13
2	565.30.030.200	x 0,5 mm	33	100.01.020.000	2
3	0835 100351	4	40	0912 060253	6
4	0331 100003	4	41	0912 060203	3
5	565.30.006.000	1	42	0912 060163	2
6	565.30.036.000	1	43	0137 060000	9
7	565.30.079.000	8			
8	565.30.080.000	8			
10	563.30.051.044	1			
11	563.30.051.000	1			
12	563.30.052.000	2			
13	563.30.053.000	2			
14	0084 040083	8			
15	563.30.050.000	1			
16	565.30.061.000	1			
20	543.05.073.000	1			
21	543.30.046.000	1			
22	510.05.074.000	1			

x = NACH BEDARF
as required

VERGASER / Carburettor

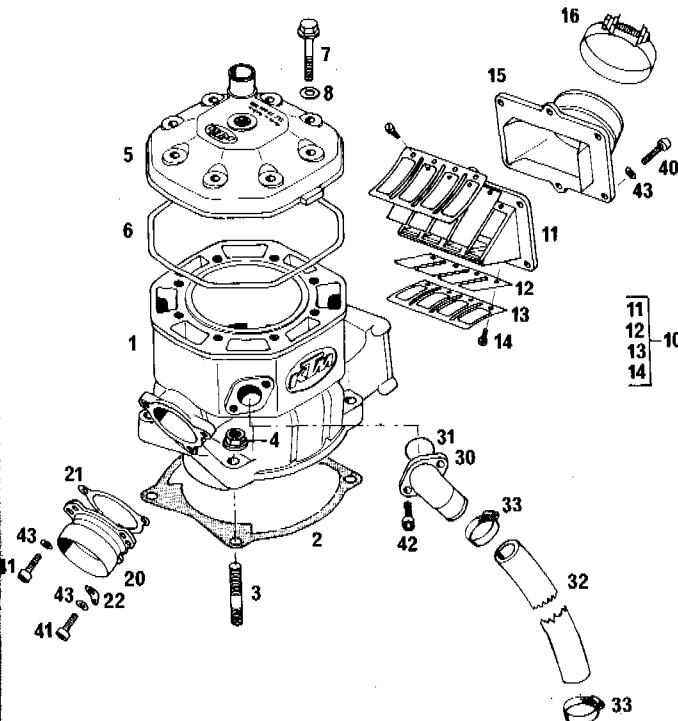

BILD Fig.	TEILENUMMER Part number	STK Qty	BILD Fig.	TEILENUMMER Part number	STK Qty
1	565.31.101.044	1	32	0244 182 000	1
	BING 55/38/101		34	564.31.134.000	1
7	520.31.107.0...*	1		6 L 6	
8	520.31.108.000	1	35	564.31.135.160	1
9	520.31.209.000	1		NR.160	
10	564.31.110.000	1	36	540.31.236.000	1
11	564.31.111.000	1		NR.2	
12	563.31.112.000	1	37	520.31.137.000	2
13	563.31.113.000	1	38	520.31.138.000	1
14	520.31.114.000	1	41	510.31.041.000	1
16	510.31.116.100	1	42	510.31.042.000	1
17	510.31.217.000	1	43	510.31.043.000	1
18	564.31.118.000	1	45	564.31.145.000	1
19	564.31.119.000	1			
20	510.31.120.000	1			
21	510.31.121....*	1			
22	564.31.122.000	1			
23	520.31.123....*	1			
24	564.31.124.000	1			
25	520.31.125.000	1			
26	520.31.126.000	1			
27	564.31.127.000	1			
28	564.31.128.000	1			
30	564.31.130.000	1			
31	564.31.131.000	1			

*BITTE GRÖSSE ANGEBEN !
Please quote size !

ZÜNDANLAGE / Ignition system

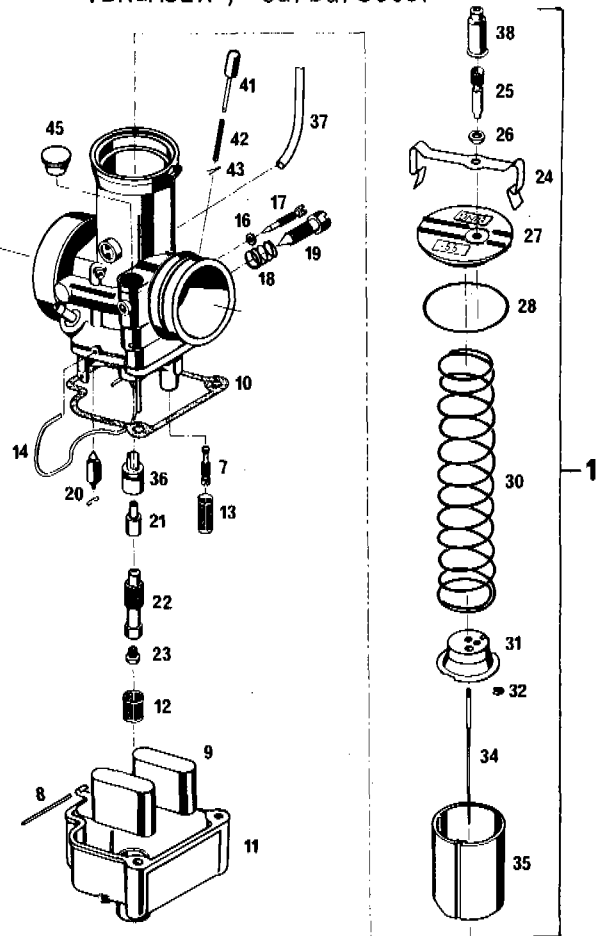

BILD Fig.	TEILENUMMER Part number	STK Qty
2a	560.31.002.000 (9600 176-1) MX	1
2b	510.31.002.000 (9600 162-1) MXC, XC-GS	1
3	570.13.070.100	1
4	510.31.004.000	1
5	510.31.005.000	1
6	510.31.006.200	1
10	510.31.010.100	1
11	510.31.011.000	1
93	565.31.093.002 (BOSCH W 2 CC)	1
94	0933 060163	2
95	0021 060003	2
96	0985 060003	2
97	0085 040203	3
98	0085 040123	4
99	0137 040003	7

KUPPLUNG / Clutch

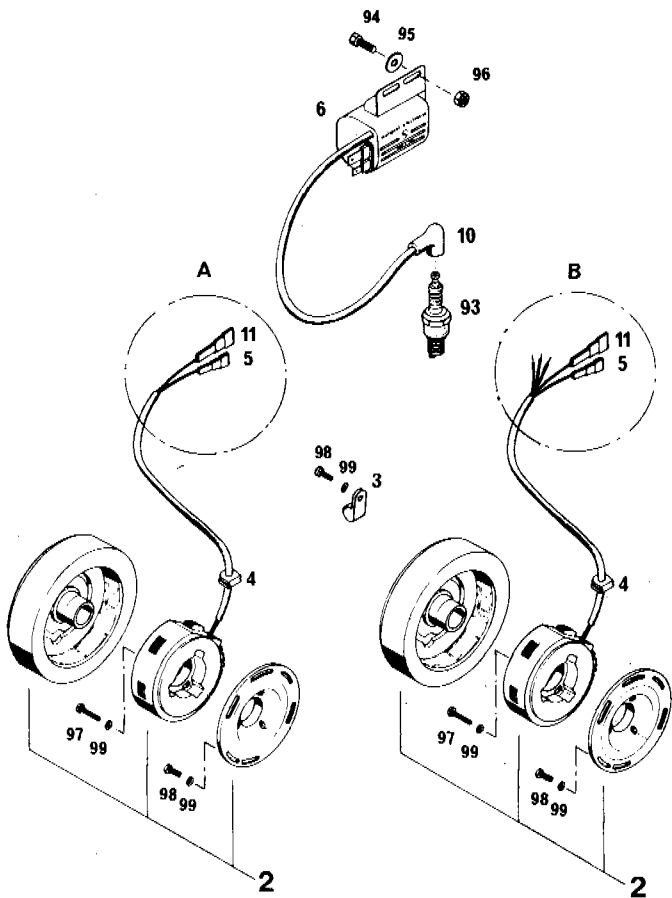

BILD Fig.	TEILENUMMER Part number	STK Qty	BILD Fig.	TEILENUMMER Part number	STK Qty
1	565.32.001.044	1	27	543.32.030.000	1
2	565.32.001.000	1	28	0471 100010	1
3	565.32.007.000	6	29	501.32.033.000	1
4	565.32.012.000	2	30	0094 150223	1
5	565.32.096.000	1			
6	565.32.095.000	1			
7	560.32.012.100	5	1,4 mm		
8	560.32.012.200	5	1,0 mm		
9	560.32.011.000	9			
10	565.32.002.000	1			
11	565.32.018.000	1			
12	0936 181505	1			
13	565.32.003.000	1			
14	544.32.001.100	6	∅ 2,7		
15	0021 060003	6			
16	0933 060203	6			
20	0912 060103	1			
21	0137 060000	1			
22	501.32.013.000	1			
23	501.32.014.000	1			
24	0770 100022	1			
25	565.32.017.000	1			
26	501.32.032.000	1			

SCHALTUNG / Shifting mechanism

BILD TEILENUMMER STK
Fig. Part number Qty

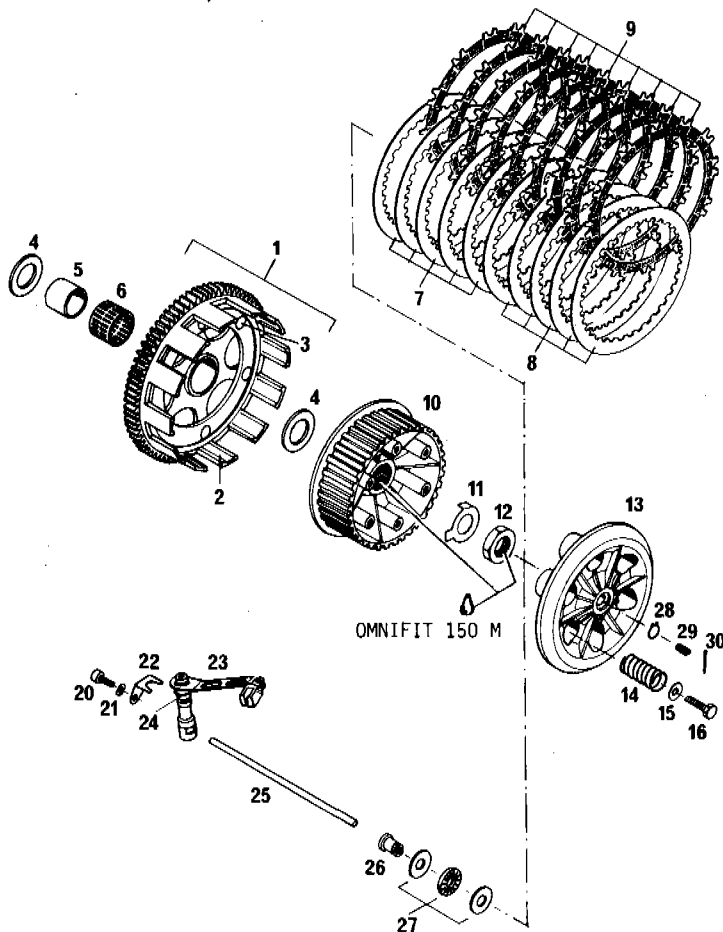
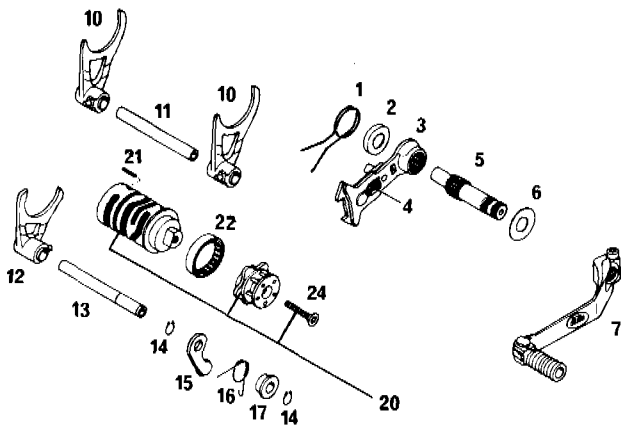

1	565.34.014.200	1
2	565.34.020.000	1
3	565.34.007.044	1
4	565.34.013.100	1
5	565.34.005.100	1
6	500.30.048.000	1
7	565.34.022.000	1
10	565.34.002.100	2
11	565.34.004.000	1
12	565.34.001.100	1
13	565.34.003.000	1
14	0471 100010	2
15	565.34.024.044	1
16	565.34.023.000	1
17	565.34.021.000	1
20	565.34.012.044	1 4-GANG / 4-speed
20	565.34.012.045	1 5-GANG / 5-speed
21	0402 031580	1 4-GANG / 4-speed
22	501.34.026.000	1
24	565.34.016.000	1

KÜHLSYSTEM / Cooling system

BILD TEILENUMMER STK
Fig. Part number Qty

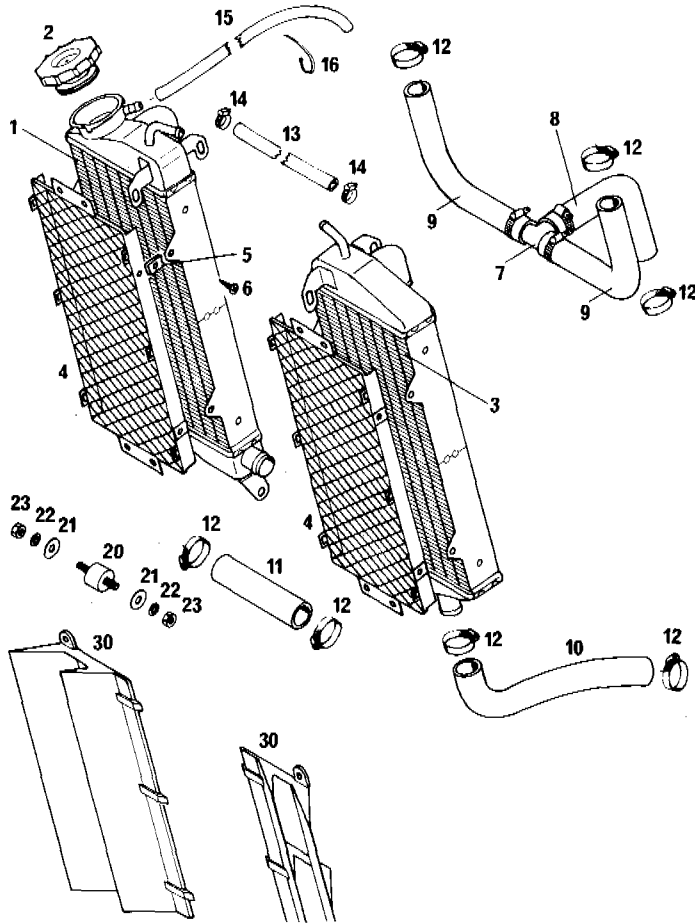

1	565.35.008.000	1
2	500.35.616.000	1
3	565.35.007.000	1
4	565.35.030.000	2
5	310.05.042.000	8
6	0983 480163	4
7	565.35.026.000	1 \varnothing 15/18/15
8	565.35.027.000	1 \varnothing 18
9	565.35.127.000	2 \varnothing 15
10	565.35.037.000	1 \varnothing 18
11	565.35.025.001	0,1 \varnothing 18
12	100.01.020.000	10
13	544.35.024.001	0,13
14	420.13.037.000	2
15	550.07.016.001	0,45
16	440.11.076.155	x
20	543.35.031.000	6
21	0021 060003	12
22	0797 060003	12
23	0934 060003	12
30	565.35.034.000	2

x = NACH BEDARF / as required

KICKSTARTER / Kickstarter



BILD Fig.	TEILENUMMER Part number	STK Qty
1	565.33.027.000	1
2	565.33.023.000	1
3	565.33.021.000	1
4	501.33.090.000	1
5	501.33.015.000	1
6	565.33.022.000	1
7	565.33.024.000	1
8	565.33.026.000	1
9	565.33.020.500	1
10	565.33.036.044	1

GETRIEBE I / Transmission I

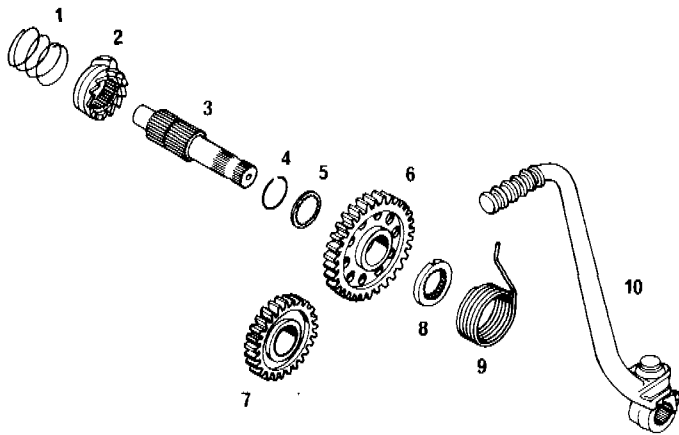

BILD Fig.	TEILENUMMER Part number	STK Qty
1	565.33.002.000	1 14-Z
2	565.33.010.000	1 15-Z MXC, XC-GS
2	565.33.110.000	1 16-Z MX
3	565.33.004.000	1 18-Z
4	565.33.006.000	1 20-Z
5	565.33.008.000	1 27-Z
6	565.33.016.000	2 2 mm
7	565.33.116.000	x 3 mm
8	565.33.015.000	1
9	565.33.099.000	2
10	520.33.096.000	2
11	0625 201029	1
12	565.33.093.000	1

GETRIEBE II / Transmission II

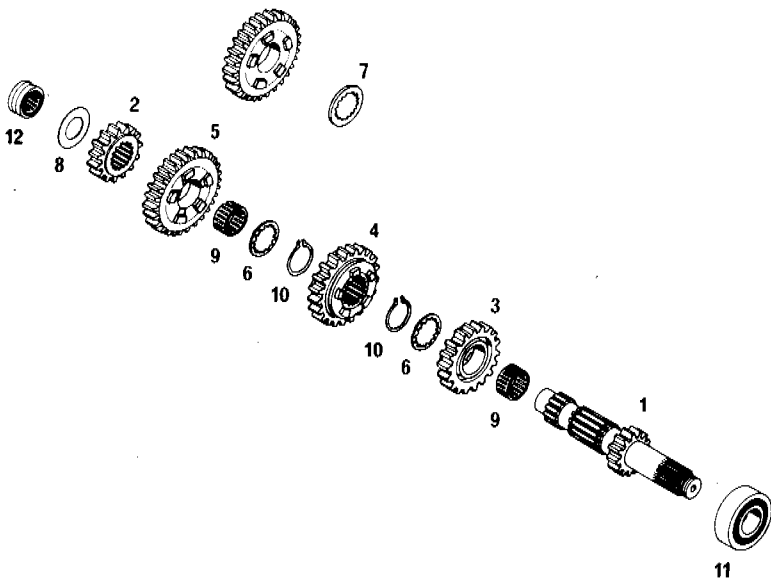

BILD Fig.	TEILLNUMMER Part number	STK Qty
0	565.33.019.000	1 4G
1	565.33.005.000	1 5G 35-Z
2	565.33.013.000	1 24-Z
3	565.33.007.000	1 21-Z
4	565.33.009.000	1 19-Z
5	565.33.011.000	1 21-Z MX
5	565.33.111.000	1 20-Z MXC XC-GS
6	565.33.003.000	1
7	500.33.001.000	1
8	565.33.015.000	1
9	565.33.018.000	1 5G
10	565.33.016.000	1
11	565.33.014.000	2
12	520.33.096.000	3
13	520.33.090.100	1
14	565.33.017.000	1
15	565.33.099.000	1 4G 2 5G
16	565.33.093.000	1
17	0625 062058	1
18	560.33.020.000	1
19	0770 020220	1
20	501.33.018.000	1
21	0760 324770	1
22	500.33.029.014	1 14-Z
22	500.33.029.013	x 13-Z
25	500.30.076.000	1

4G = 4-GANG / 4-speed
5G = 5-GANG / 5-speed

x = NACH BEDARF
as required

SPEZIALWERKZEUGE / Special tools

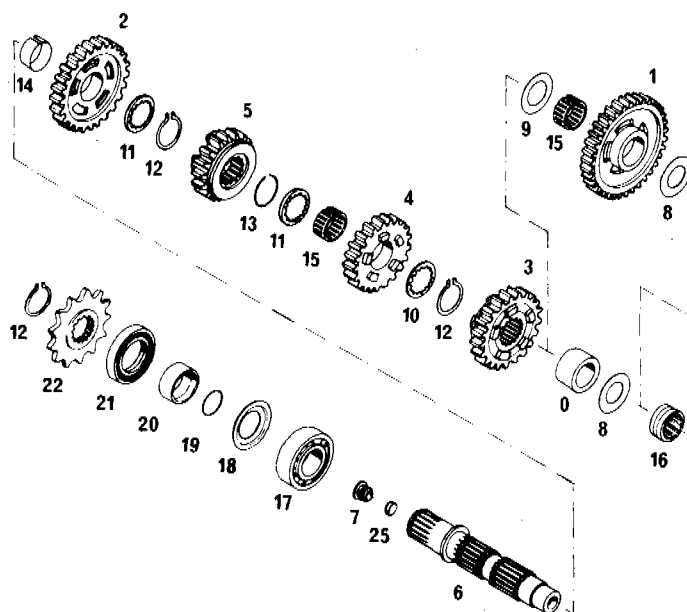

BILD Fig.	TEILENUMMER Part number	STK Qty
1	560.12.001.000	1
2	565.12.001.050	1
3	560.12.003.000	1
4	560.12.004.000	1
5a	501.12.005.000	1 ø15
5b	565.12.005.014	1 ø14
5c	565.12.005.017	1 ø17
5d	565.12.005.032	1 ø32
9	520.12.009.000	1
10	520.12.010.000	1
11	520.12.011.000	1
14	510.12.014.000	1
16	510.12.016.000	1
23	SELBSTGEFERTIGT self-made	1
25	501.12.013.000	1
26	501.12.030.000	1
27	510.12.012.000	1

MOTOR TYP 565
Engine Type 565 '85
500 cc

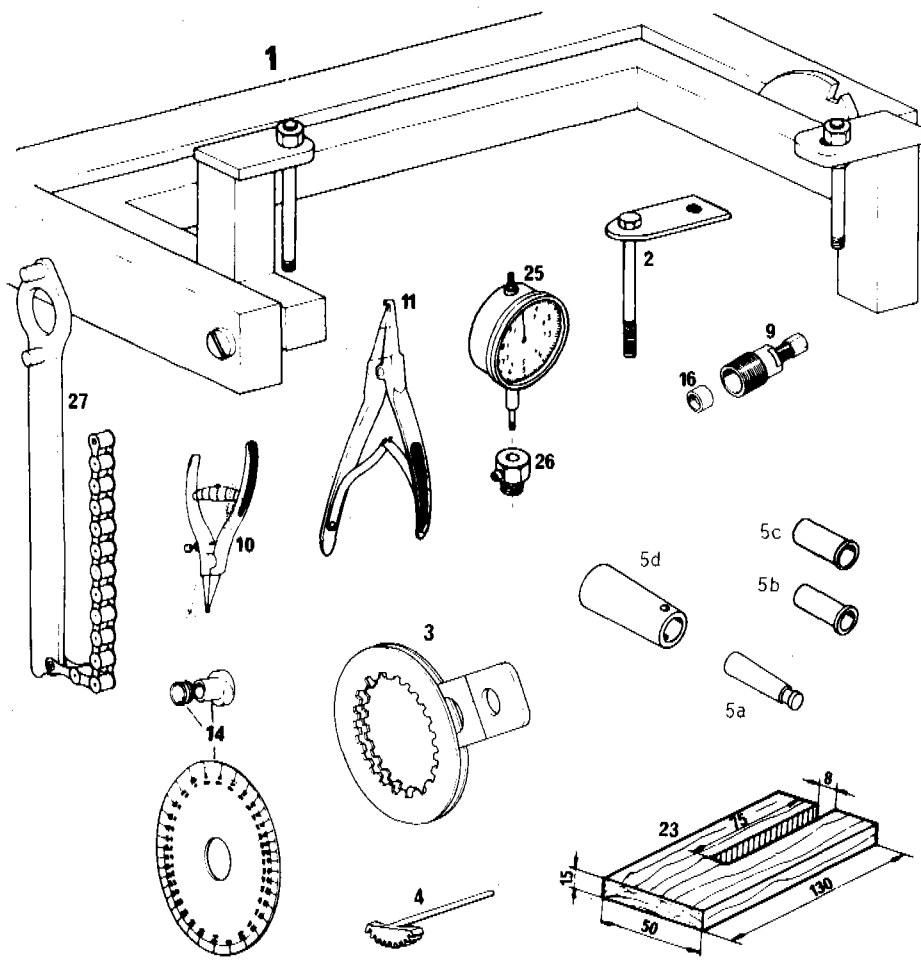
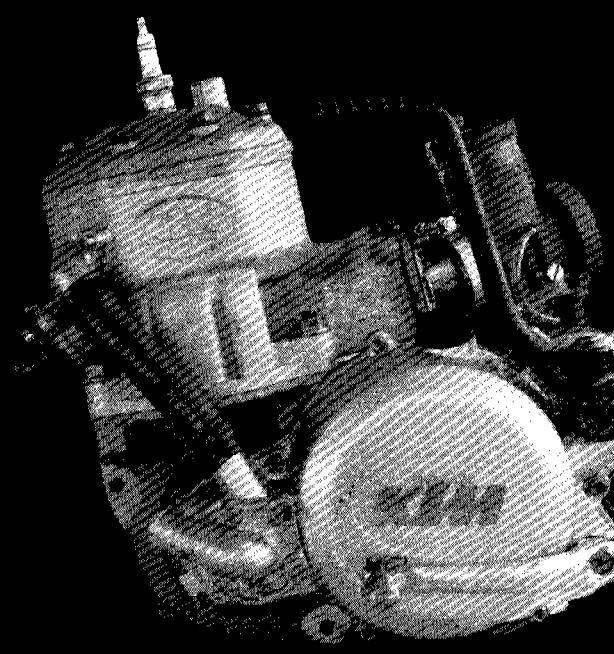

KTM Motor · Fahrzeugbau KG
Erich Trunkenpolz
A-5230 Mattighofen · Austria